



Kaifeng Huabang Instrument Co., Ltd.
Turbine flow meter selection book

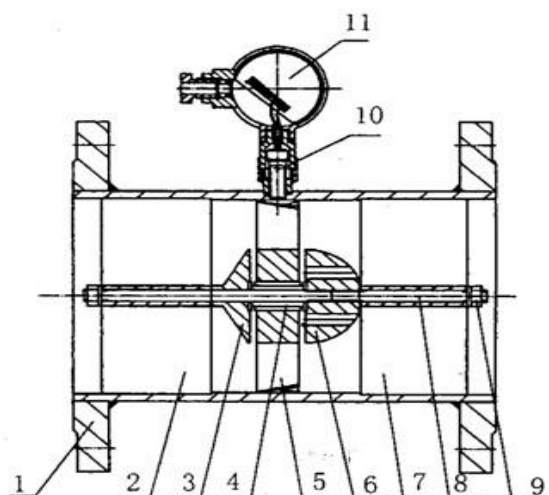

Table of Contents

product description.....	- 3 -
working principle.....	- 3 -
Features.....	- 4 -
Technical parameter.....	- 5 -
Installation Precautions.....	- 7 -
Product Exhibition.....	- 8 -
Product size chart.....	- 9 -
LWGY Pipe Turbine Flowmeter Selection Table.....	- 11 -

product description

The LWGY series turbine flowmeter is a new generation of turbine flowmeter that has absorbed the domestic and foreign flow meter cash technology and has been optimized and designed. It has the characteristics of simple structure, light weight, high precision, good reproducibility, responsiveness, easy installation and maintenance, and is widely used. In the measurement of closed pipes, it has no corrosion effect with stainless steel 1Cr18Ni9Ti, 2Cr13 and corundum Al_2O_3 , cemented carbide, and has no impurities such as fibers and particles. The kinematic viscosity at operating temperature is less than $5 \times 10^{-6} m^2/s$. For kinematic viscosity greater than $5 \times 10^{-6} m^2/s$ liquid can be used after the liquid calibration of the flowmeter. If it is matched with a display instrument with special functions, it can also perform quantitative control and over-alarm alarm, etc. It is an ideal instrument for flow measurement and energy saving.



1. Housing 2. Flow guide 3. Cone 4. Bearing system 5. Impeller 6. Thrust body 7. Flow guide 8. Long shaft 9. Nut
10. Signal monitor 11. Amplifier

Figure 1 Schematic diagram of LWGY basic liquid turbine flow sensor

working principle

(1) When the measured fluid flows through the sensor, under the action of the fluid, the impeller is forced to rotate, its speed is proportional to the average flow rate of the pipe, and the rotation of the impeller periodically changes the reluctance value of the magnetoelectric converter. The magnetic flux in the detection coil then changes periodically, generating a periodic induced potential, that is, an electrical pulse signal, amplified by the amplifier, and sent to the display instrument for display.

(2) Turbine flowmeter flow equations can be divided into two types: practical flow equations and theoretical flow equations.

(3) Practical flow equation

$$qv=f/k$$

$$qm=qvp$$

In the formula

qv , qm Respectively, volume flow, m³/s, mass flow, Kg/s;

F ...the frequency of the flowmeter output number, Hz;

K ...the meter factor of the flowmeter, p/m³.

(2) The theoretical flow equation

The equation of motion of the impeller can be listed according to the momentum theorem

$$J=dw/dt-M1-M2-M3-M4$$

In the formula

J : moment of inertia of the impeller;

dw/dt : rotational acceleration of the impeller;

$M1$: driving torque of the fluid;

$M2$: viscous drag torque;

$M3$: Bearing friction resistance torque;

$M4$: Reluctance torque.

When the impeller rotates at a constant speed, $JX=0$, then $M1=M2+M3+M4$

Available through theoretical analysis and experimental verification

$$n=Aqv+B-$$

In the formula

n : impeller speed;

qv : volume flow;

A : With the fluid properties (density, viscosity, etc.), impeller structure parameters

(Blade inclination angle, impeller diameter, flow channel cross-sectional area, etc.) related parameters;

B : Coefficient related to blade tip clearance and fluid velocity distribution;

C : Coefficient related to friction torque.

Features

- ❖ High accuracy, generally up to $\pm 1\%R$, $\pm 0.5\%R$, high precision type up to $\pm 0.2\%R$;
- ❖ Good repeatability, short-term repeatability can reach $0.05\% \sim 0.2\%$, precisely because of good repeatability, such as frequent calibration or online calibration can get extremely high accuracy, is the preferred flowmeter in trade settlement;
- ❖ Output pulse frequency signal, suitable for total measurement and computer connection, no zero drift, strong anti-interference ability;
- ❖ High frequency signal ($3 \sim 4\text{kHz}$) can be obtained with strong signal resolution;
- ❖ Wide range, medium and large caliber up to 1:2, small caliber 1:10;
- ❖ Compact and lightweight structure, easy installation and maintenance, and large circulation capacity;
- ❖ High-pressure measurement is used, and there is no need to make holes in the meter body, so it is easy to make a high-pressure meter;
- ❖ There are many types of special sensors, which can be designed as various special sensors according to the special needs of users, such as low temperature type, bidirectional type, downhole type, sand mixing type, etc.;
- ❖ Can be made into insert type, suitable for large-diameter measurement, low pressure loss, low price, continuous flow removal, easy installation and maintenance

Technical parameter

Project	Technical parameter
Executive Standard	Turbine flow sensor (JB/T9246~1999)
Instrument caliber (mm) and connection method	4, 6, 10, 15, 20, 25, 32, 40 use screw connection (15, 20, 25, 32, 40) 50, 65, 80, 100, 125, 150, 200 use flange connection
Accuracy class	$\pm 1\%R$, $\pm 0.5\%R$, $\pm 0.2\%R$ (special needs)
Range ratio	1:10; 1:15; 1:20
Sensor material	304 stainless steel, 316 (L) stainless steel, etc.
Conditions of Use	Medium temperature: $-20^{\circ}\text{C}\sim+120^{\circ}\text{C}$ Ambient temperature: $-20^{\circ}\text{C}\sim+60^{\circ}\text{C}$ Relative humidity: $5\% \sim 90\%$ Atmospheric pressure: 86Kpa~106Kpa
Signal output function	Pulse signal, 4~20mA signal
Communication output function	RS485 communication, HART protocol, etc.
Working power	A、 External power supply: $+24\text{VDC}\pm 15\%$, shading $\leq \pm 5$, suitable for 4-20mA output, pulse output, RS485, etc. B、 Internal power supply: 1 set of 3.0V10AH lithium battery, the battery voltage can work normally when the voltage is 2.0V~3.0V
Signal line interface	Basic type: Hausmann connector or its own three-core cable; explosion-proof type: internal thread M20×1.5
Explosion-proof grade	ExialICT4 or ExdIIBT6
Protection class	IP65 or higher (customizable)

Measuring range and working pressure

Instrument caliber (mm)	Normal flow range (m ³ /h)	Extended flow range (m ³ /h)	Conventional connection method and pressure rating	Specially made withstand voltage level (Mpa) (flange clamp)
DN4	0.04~0.25	0.04~0.4	Thread connection/6.3Mpa	10、16、25
DN6	0.1~0.6	0.06~0.6	Thread connection/6.3Mpa	10、16、25
DN10	0.2~1.2	0.15~1.5	Thread connection/6.3Mpa	10、16、25
DN15	0.6~6	0.4~8	Thread connection/6.3Mpa	4.0、6.3、10、16、25
			Thread connection/2.5Mpa	
DN20	0.8~8	0.45~9	Thread connection/6.3Mpa	4.0、6.3、10、16、25
			Thread connection/2.5Mpa	
DN25	1~10	0.5~10	Thread connection/6.3Mpa	4.0、6.3、10、16、25
			Thread connection/2.5Mpa	
DN32	1.5~15	0.8~15	Thread connection/6.3Mpa	4.0、6.3、10、16、25
			Thread connection/2.5Mpa	
DN40	2~20	1~20	Thread connection/6.3Mpa Thread connection/2.5Mpa	4.0、6.3、10、16、25
DN50	4~40	2~40	Thread connection/2.5Mpa	4.0、6.3、10、16、25
DN65	7~70	4~70	Thread connection/2.5Mpa	4.0、6.3、10、16、25
DN80	10~100	5~100	Thread connection/2.5Mpa	4.0、6.3、10、16、25
DN100	20~200	10~200	Thread connection/1.6Mpa	2.5、4.0、6.3、10、16、25
DN125	25~250	13~250	Thread connection/1.6Mpa	2.5、4.0、6.3、10、16
DN150	30~300	15~300	Thread connection/1.6Mpa	2.5、4.0、6.3、10、16
DN200	80~80	40~800	Thread connection/1.6Mpa	2.5、4.0、6.3、10、16

Installation Precautions

1. Before installing the sensor, connect the display instrument or oscilloscope, turn on the power, and turn the impeller with a mouth blower or hand to make it rotate quickly. Observe whether there is a display. When installing when there is a display, check each part to exclude malfunction;
2. When the sensor is used, the sensor should be filled with liquid slowly before opening the outlet valve;
3. When the sensor is not in use, the inside should be cleaned, and the general maintenance cycle is half a year; when overhauling, do not pay attention to not damage the impeller assembly in the table;
4. Corrosion effect: The user should fully understand the corrosion of the measured medium to prevent the sensor from being corroded

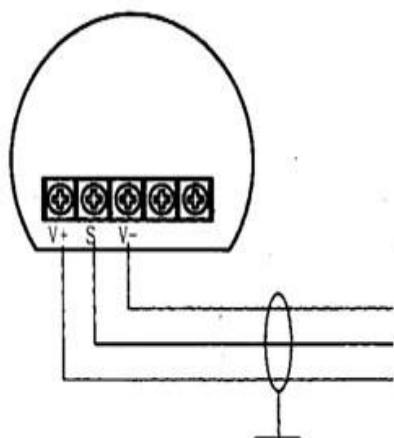

Connect to power ground (shared with display instrument input)

Press display instrument input

Connect to external power supply or display instrument(+24v)

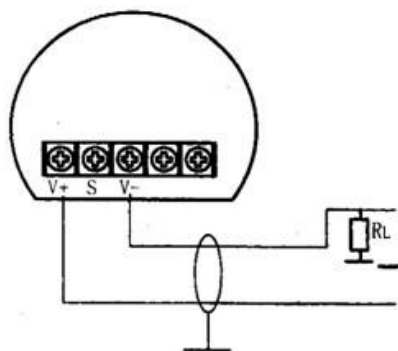

Press display instrument input

Connect to power ground (shared with display instrument input)

Connect to external power supply or display instrument(+24v)

Product Exhibition



Flange connection turbine flowmeter | Clamp connection turbine flowmeter | Screw connection turbine flowmeter | Screw connection turbine flowmeter

Intelligent integrated turbine flowmeter

Intelligent integrated turbine flowmeter

A new type of intelligent instrument integrating turbine flow sensor and display integration with advanced ultra-low power monolithic microcomputer technology. It adopts dual-row LCD on-site display. It has compact mechanism, intuitive and clear reading, high reliability, and is not subject to external power supply. Obvious advantages such as interference, anti-lightning strike, and low cost. The instrument has three-point correction of the instrument coefficient, intelligently compensates the non-linearity of the instrument coefficient, and can be corrected on site. High-definition LCD monitor colleagues display instantaneous flow rate (4 significant digits) and accumulated flow rate (8 significant digits, with clear function). All valid data will not be lost for 10 years after power off. This type of turbine flowmeter is an explosion-proof product with an explosion-proof grade of Exd II BT6.

This type of turbine flowmeter can be divided into LWGY-□B type and LWGY-□C type according to the power supply mode and whether it has remote transmission signal output.

LWGY-□B type: The power supply uses 3.0V10AH lithium battery (can run continuously for more than four years, without signal output function).

LWGY-□C type: The power supply uses 24VDC external power supply, and outputs 4-20mA standard two-wire, three-wire, four-wire current signals, or 1~5V voltage signals, and RS485 or HART can be added according to different scenarios. communication.

Product size chart

Turbine flowmeter size



图2 螺纹连接结构



图3 法兰连接结构

Product size chart

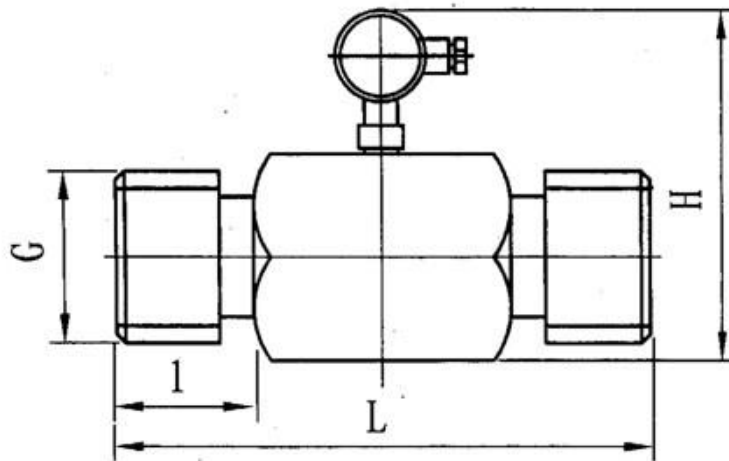
Unit: mm

Nominal diameter DN (mm)		4	6	10	15	20	25	32	40	50	65	80	100	125	150	200
sensor																
Dimension L		225	225	345	75	85	100	120	140	150	150	200	220	250	300	360
s (mm)																
H	H	145	145	170	190	210	230	250	260	270	290	300	330	380	390	455
	D				95	105	115	140/135	150/145	165/160	185/180	200/195	220/215	250/245	285/280	340/335
Flange size (Mm)	D1				65	75	85	100	110	125	145	160	180	210	240	295
	D2				45	55	65	78	85	100	125	135	155	185	210	265
	D3															
n-d0	n-d0				4-14	4-14	4-14	4-18	4-18	4-18	4-18	8-18	8-18	8-18	8-23	12-23
	L1 (mm)				23	23	30	30	35							
Pipe thread size	G	1/2	1/2	1/2	1	1	1 1/4	1 1/4	2							

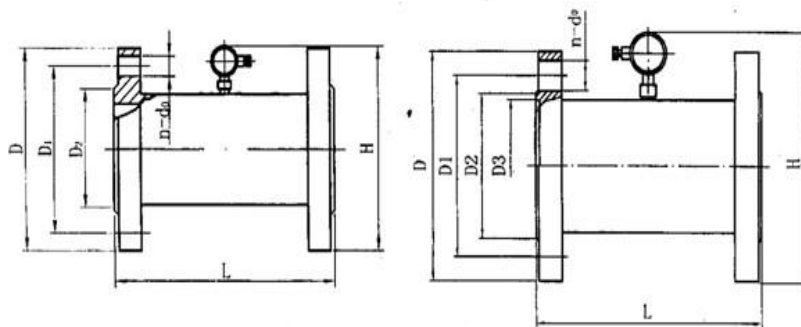
LWGY Pipe Turbine Flowmeter Selection Table

model								Explanation
HBLWGY	□	/□	/□	/□	/□	/□	/□	
Nominal diameter	4							4mm
	6							6mm
	10							10mm
	15							15mm
	20							20mm
	25							25mm
	32							32mm
	40							40mm
	50							50mm
	65							65mm
	80							80mm
	100							100mm
	125							125mm
	150							150mm
200							200mm	
Instrument type	N							Sensor type: +12V or 24V power supply, output three-wire pulse signal
	A							Transmitter type: +24V power supply, output 2-wire 4~20mA
	B							Intelligent type: Lithium battery power supply, no signal output on site display
	C							Intelligent type: +24V power supply, on-site display and output 2-wire 4~20mA
	C1							Intelligent type: +24V power supply, on-site display with RS485 communication output
	C2							Intelligent type: +24V power supply, on-site display and with HART communication protocol
Accuracy class	5							0.5 level
	10							1.0 level
	2							0.2 level (negotiation order, longer production cycle)
Turbine type						W		Extended measuring range
						S		Standard measuring range
Turbine type							S	304 stainless steel
							L	316 (L) stainless steel
Explosion-proof							N	Non-explosion-proof
							E	Explosion-proof type, Exd II BT6
Pressure Level							N	conventional
							H(X)	high pressure
<p>Note 1: DN15~DN40 are conventionally threaded connections, if you want to use flange connection, please add "(FL)" after "nominal diameter" For example: choose a flange connection type explosion-proof turbine flow meter to measure diesel, The pipeline is DN40, and the two-wire current signal needs to be displayed and remotely transmitted on site. The accuracy is 0.5, 304 stainless steel, and the instrument's pressure resistance is 16Mpa. The measurement range is standard range, and its product model should be: LWGY-40 (FL)/C/05/ S/S/E/H16</p>								
<p>Note 2: When selecting C-type instrument, users can choose two-wire system, three-wire system or four-wire system. If not specified, the default is two-wire system model representation</p>								
<p>Two-wire 4-20mA LWG-40 (FL) C/05/S/S/E/H16 three-wire 4-20mA LWYG-40 (FL) C-3/05/S/S/E/H16 four-wire 4-20mA LWYG-40(FL)C-4/05/S/S/E/H16</p>								



Survive by quality, seek development by integrity

Kaifeng Huabang Instrument Co., Ltd.

KAIFENG HUABANG INSTRUMENT CO.,LTD

Factory Address: North Section of Shanghe Avenue, Xiangfu District, Kaifeng City, Henan Province

Phone: 86-0371-26680208

Email: hbflowmeter@163.com

Website: <http://www.kfhbyb.com>